

Professional custom-made explosion-proof distribution boxes

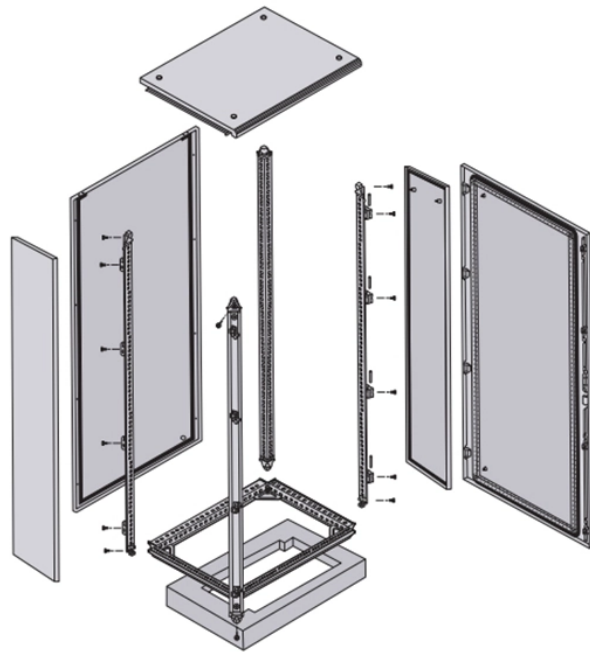

Professional custom-made explosion-proof distribution boxes



Safely conduct, connect and distribute energy in hazardous areas with R. STAHL's terminal boxes. We offer bespoke, custom-made terminal boxes and terminal box combinations, as well as standard ...

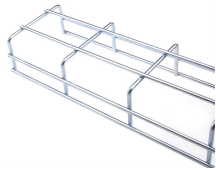

Investing in a high-quality explosion proof distribution box is essential for meeting strict international safety regulations and protecting personnel from potential electrical hazards.



Warom is a professional Explosion Proof Distribution Cabinets manufacturer, providing industrial and hazardous area electrical solutions. Our customizable distribution panels support high-voltage ...



EWJ are a professional metal enclosure manufacturer providing electrical enclosures, aluminum enclosures, stainless steel junction boxes, and IP65 outdoor enclosure solutions.



Atex control stations, explosion protected control units and distribution boxes made stainless steel maritime grade AISI 316L or AISI 304L. Atex Delvalle provides a custom build facility for Hazardous ...



Custom Explosion-Proof Distribution Boxes for Mines Mulan Group delivers rugged, ATEX-certified electrical enclosures custom -built for mining operations. OEM/ODM support from ...

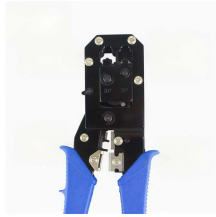

Durable Hexlon Explosion Proof Distribution Boxes and Electrical Enclosures, IECEx and ATEX certified for Zone 1 and Zone 2.

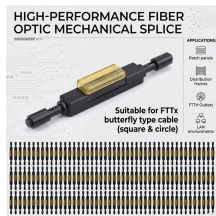

As a flameproof box manufacturer, SUREALL provides different types of explosion proof boxes and fittings. SUREALL innovated the advanced machining and testing technology to ensure the quality of ...



Take control of your electrical safety today with this complete set of customized distribution boxes. Choose an explosion-proof distribution box for reliable power distribution, easier maintenance, and ...



Explosion proof distribution box components for use in hazardous areas - Zone 1 and 2; Zone 21 and 22.

Contact Us

For more information, pricing, or custom solutions, please contact us:

Website: <https://www.samastersbaseball.co.za>

Email: sales@samastersbaseball.co.za

Phone: +27 63 874 2095

Address: 15 Innovation Drive, Technopark, Stellenbosch, 7600, South Africa

This document is for informational purposes only. Specifications subject to change without notice.

